

Trinity AX1

Automated Pallet System for
Small/Medium Vertical Machining Centers



Unlock the Potential of Your CNC

AX
SERIES

Optimize Your Spindle
Reduce Your Setup Time
Run Unmanned

 **TRINITY**
ROBOTICS AUTOMATION

Trinity AX1

Automated Pallet System for
Small/Medium Vertical Machining Centers

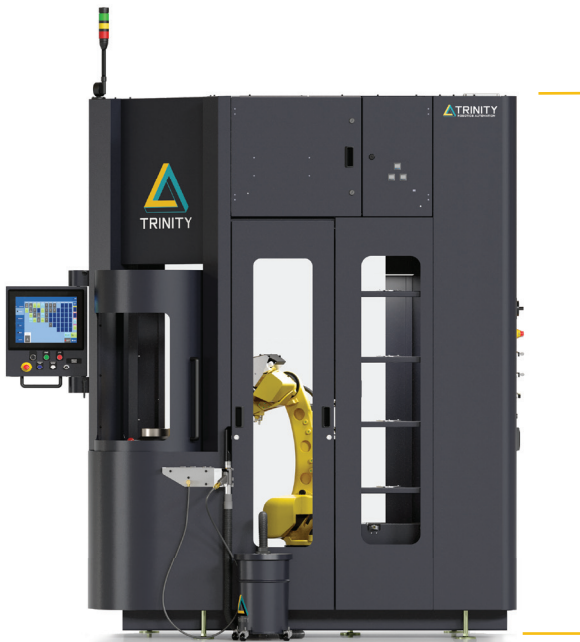

Designed & Built in California

SPECIFICATIONS

- Configurations: AX1-14 / AX1-28
- Max Part Size: $\varnothing 12'' \times 9''H / \varnothing 8'' \times 9''H$ (+ Bonus \varnothing)
- Pallet Locations: 14 / 28
- Robot Capacity: 17 lbs.

FEATURES

- Fanuc M-10iD Robot
- 15" touch screen with Trinity AXPM Software
- Pallet designed for a single clamping module
- * Single pallet operator station with rotating receiver
- Complete CNC table setup including:
 - Receiver with a single clamping module
 - Integration onto CNC table
 - Clamp confirmation for pallets
 - Controls package with clamp confirmation detection
 - Blow offs for contact surfaces
- Integrated Fanuc OEM 220 VAC, 3 phase transformer
- System crating and preparation for shipment
- CNC machine integration and auto-door installation
- System installation and operator training (5 days)

AX SERIES KEY BENEFITS

- Optimize high mix CNC production
- Decrease set-up time via stored workholding
- Eliminate idle time between part loads
- Increase spindle utilization
- Maximize the floor space of your shop
- Ensure repeatability with smart workholding & software
- Run unmanned night & weekend shifts
- Easy to use interface

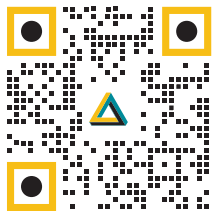

Scan QR Code to
Learn More About the
Trinity AX Series
Contact us for current
CNC compatibility

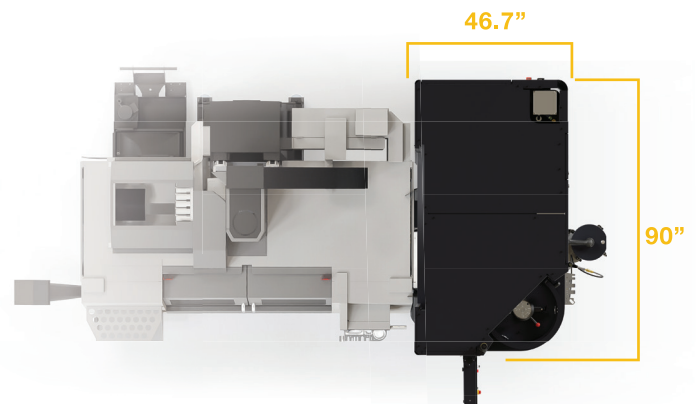

Turn your existing CNC
Machining Center into an
Automated Production
System.